

Nailing of a slope

©ZACE Services Ltd

August 2011

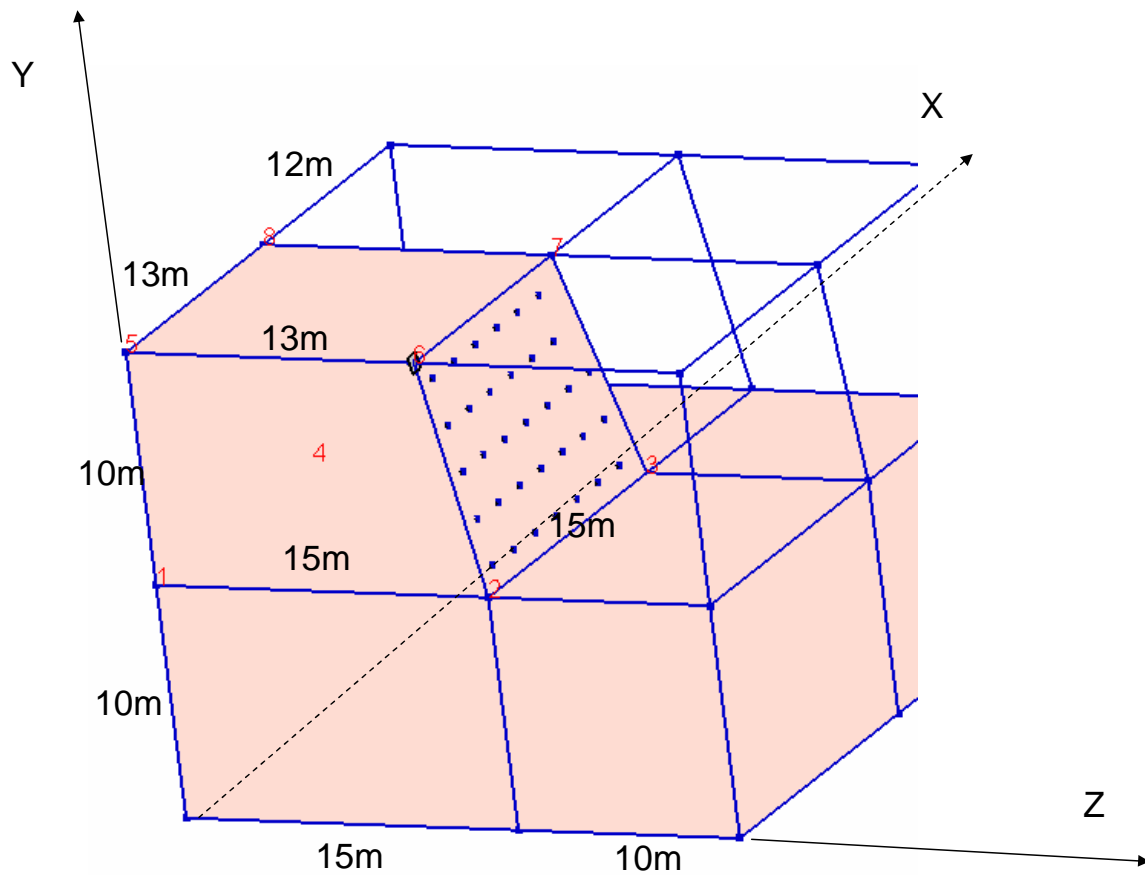



- ① We want to generate a model of a nailed slope with the given geometry
- ② This slope will be created by a multi-step excavation and simultaneous installation of nails and facing walls
- ③ 5 rows of nails will be installed (6 nails in each) on both faces of the slope
- ④ In the following slides we will see on how to construct such a data



Setting constructions lines

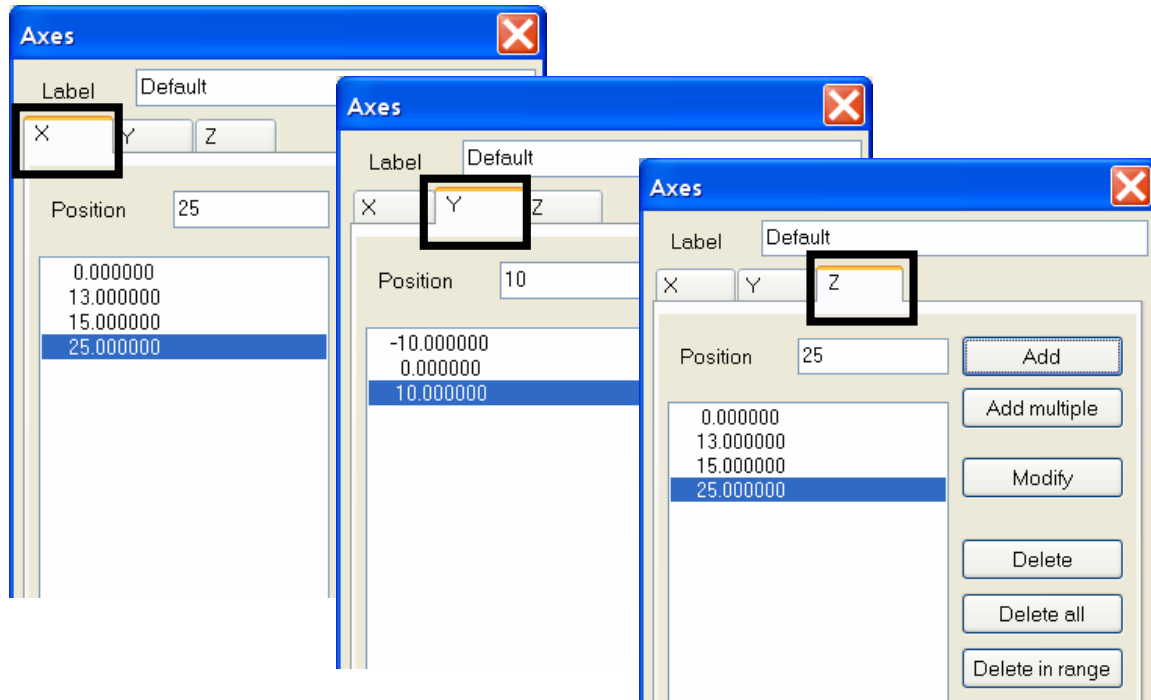

5 / 38

- 1 Open preprocessor
- 2 Use option *Settings/Construction lines*
- 3 Add points along X-axis {0.0, 13.0 , 15.0, 25.0 }
- 4 Add points along Y-axis {-10.0, 0.0 , 10.0 }
- 5 Add points along Z-axis {0.0, 13.0 , 15.0, 25.0 }
- 6 In the next slide we will draw a 2D skeleton on X-Z projection at $Y = 0.0$



6 / 38

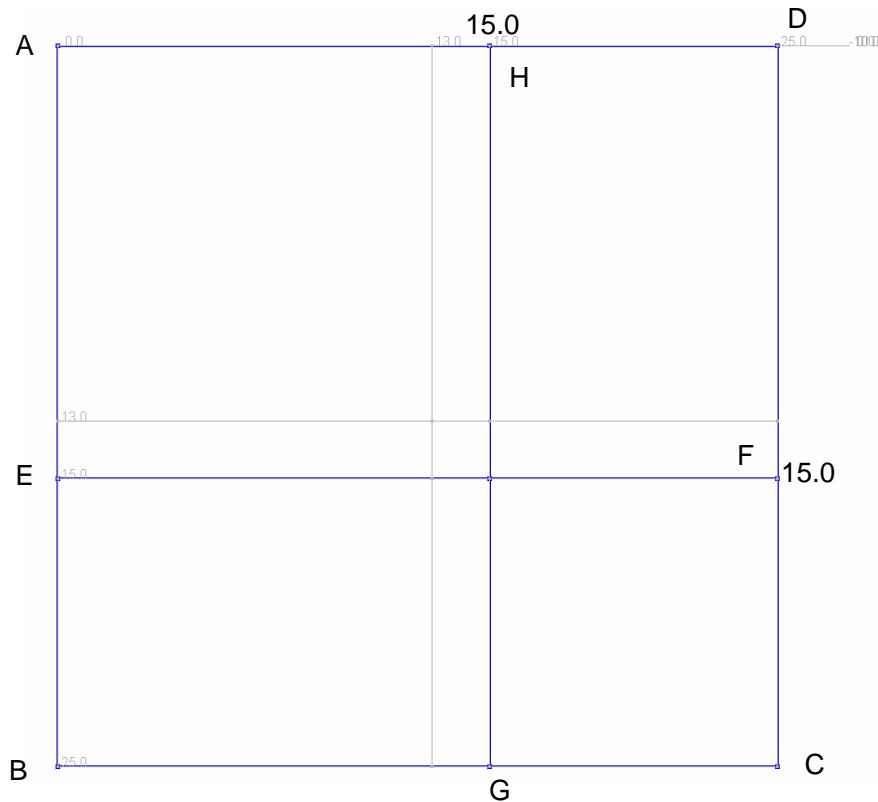

Drawing 2D skeleton lines on X-Z projection at $Y=0.0$



7 / 38

- 1 Switch to X-Z working plane by clicking the icon on the top toolbar 
- 2 Select from the adjacent to  combo-box value 0.0 (Y - level)
- 3 Draw polyline A-B-C-D (use toolbar )
- 4 Draw line E-F and answer YES if you get question whether to make an object intersection
- 5 Repeat last operation for segment G-H
- 6 In the next step we will create an auxiliary 2D subdomains that fill the 4 contours

8 / 38



Create auxiliary 2D subdomains

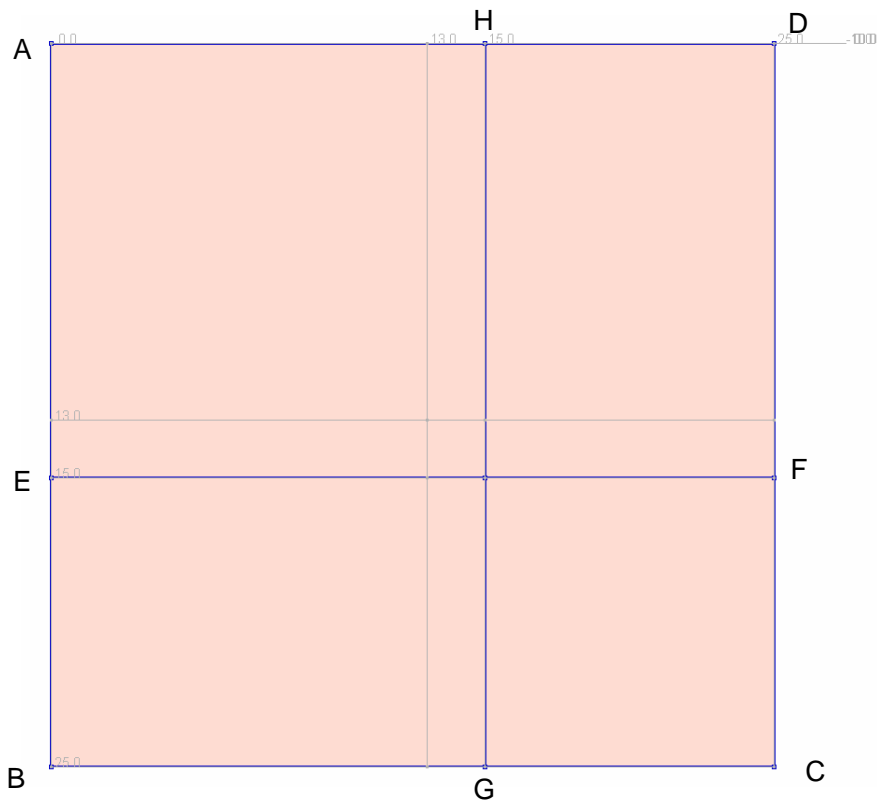

9 / 38

- 1 In the right panel menu switch to *Macromodel/Subdomain* option
- 2 Select *Create/2D continuum inside contour* method and click 4 times in the inside of 4 regions
- 3 Each time a new subdomain will be created





10 / 38

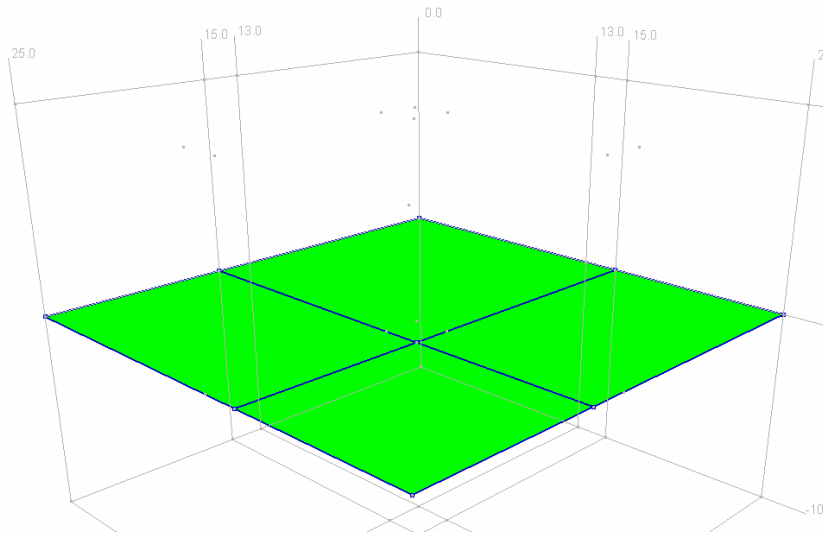

Prepare selection of auxiliary faces to perform 3D extrusion



11 / 38

- 1 Now switch to the 3D view with top toolbar 
- 2 Switch to perspective view with top toolbar 
- 3 Select 4 faces of the aux. 2D continuum by clicking them one by one using top toolbar  or all of them with zoom type selection using 

12 / 38



Perform 3D extrusion from selected faces to 3D continuum

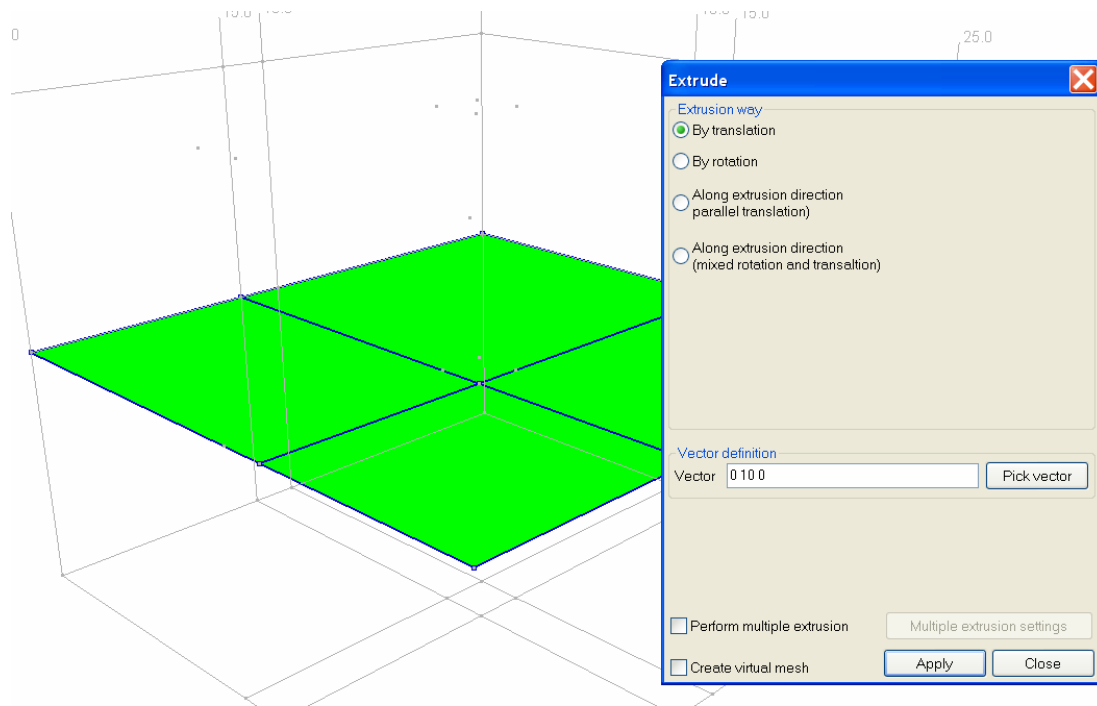

13 / 38

- 1 Go to right menu *Macromodel/Subdomain*
- 2 Select option *Create.../3D continuum/by faces extrusion*
- 3 You will get an access to the dialog box where we can define direction vector $\{0 \ 10.0 \ 0\}$
- 4 Press button **Apply** and you will get upper part of the model
- 5 On the same selection use again the option *Create.../3D continuum/by faces extrusion*, select vector $\{0 \ -10.0 \ 0\}$ and you will get bottom part of the model

14 / 38



Make correction of the geometry to form a slope

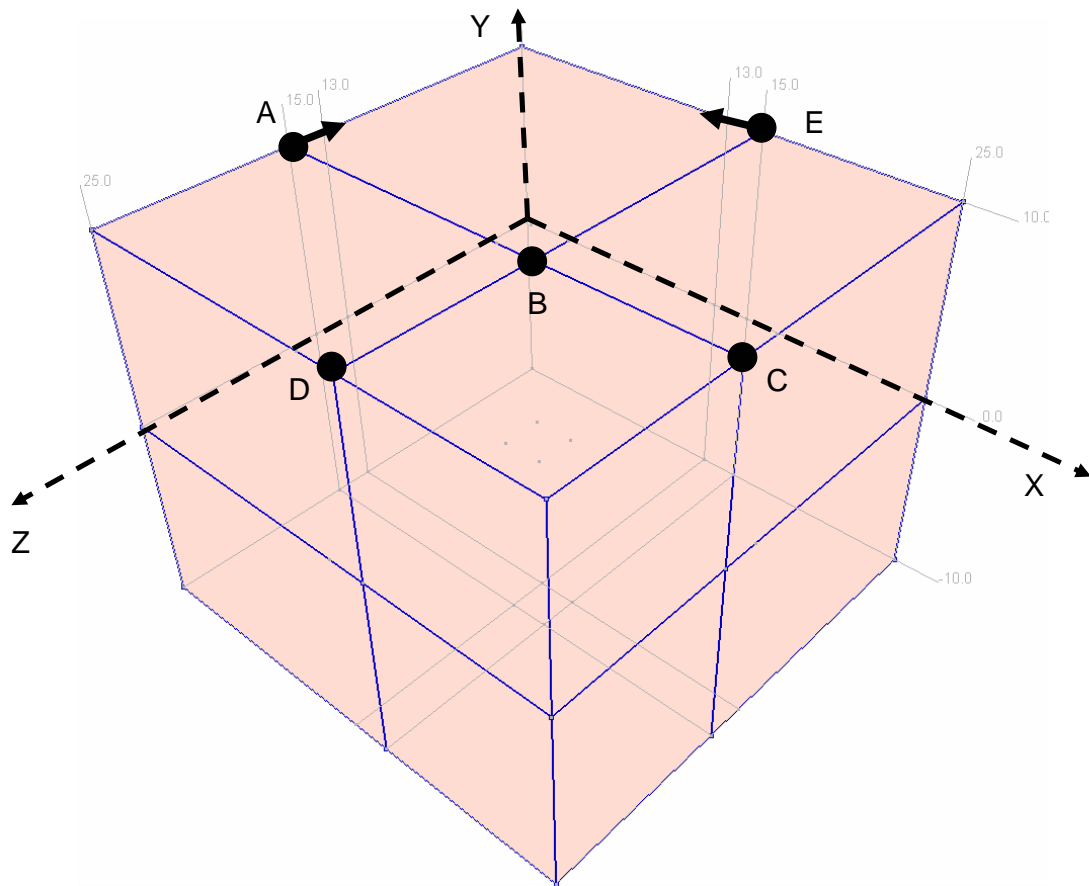

15 / 38

- 1 For better visualization of points we can hide 3D continuum by pressing Ctrl-H key (or you can alternatively do it going through the top menu *Visualization*)
- 2 Selection of points can be made by clicking point by point (use method *Macromodel/Point/Outline/Select one..*) or we can turn the whole scene to make the selection easier using zoom (use method *Macromodel/Point/Outline/In zoom box*)
- 3 Using one of the above methods select points A, B, C and shift them by the vector $\{ 0,0,-2 \}$ (to perform move operation use the method *Macromodel/Point/Update/Move Point*)
- 4 Now unselect all objects with right toolbar 
- 5 Select points e, B, F and move them in direction $\{ -2,0,0 \}$
- 6 Note that objects that are temporarily hidden but updated during points shifting will be shown

16 / 38



Let us try to create a nail

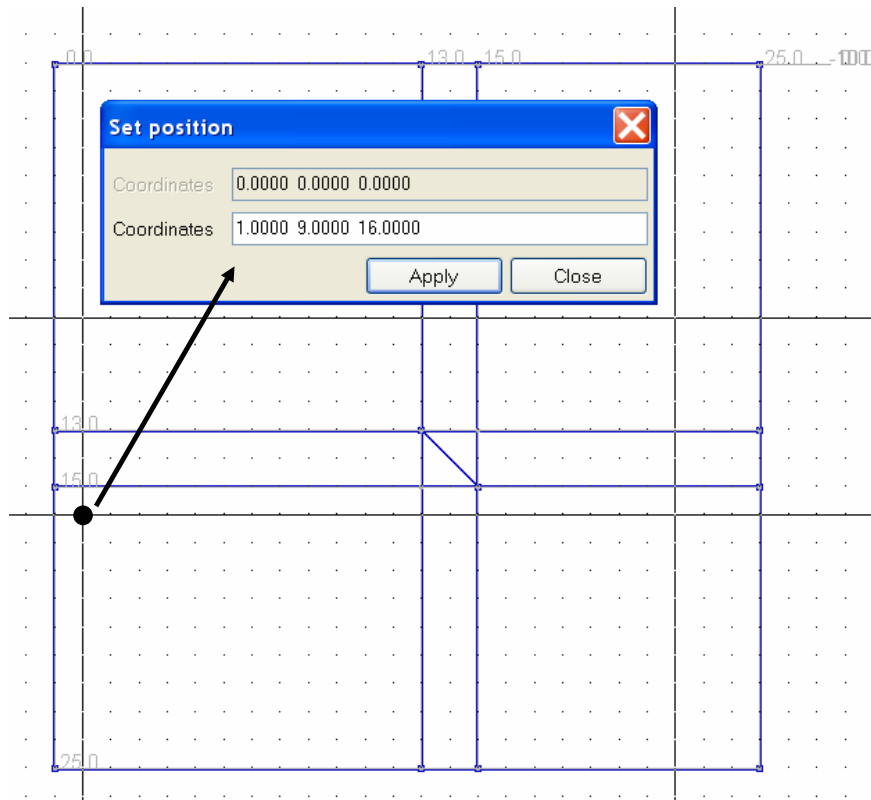

17 / 38

- 1 The first row on nails will be placed at elevation $Y=9\text{m}$
- 2 In the right menu at *Macromodel/Nail* we can find all methods on how to create a nail
- 3 In this example we will create it on a graphical object i.e. line segment
- 4 To draw this segment let us first switch to the wireframe view (press Ctrl-E or do it through the top menu *Visualization*) and switch to the X-Z projection at $Y=9\text{m}$ (this time we do not have construction line there so we type the value 9.0 and press **Enter**)
- 5 Now we will create a point that is located at $X=1.0$, $Y=9.0$ and $Z=16$ (activate grid by G shortcut if you do not see gray dots on the screen) and copy this point in the vertical direction by distance 2m (this is exactly the spacing between the nails in the vertical direction)
- 6 Create first point via *Macromodel/Point/Create/Point* method
- 7 Switch to the 3D view
- 8 Copy it using *Macromodel/Point/Create/Copy with translation* method (vector $\{ 0 -2 0 \}$)
- 9 This second point we will need in order to find a vector for multiple copies of objects in the vertical direction

18 / 38



Let us try to create a nail cont...

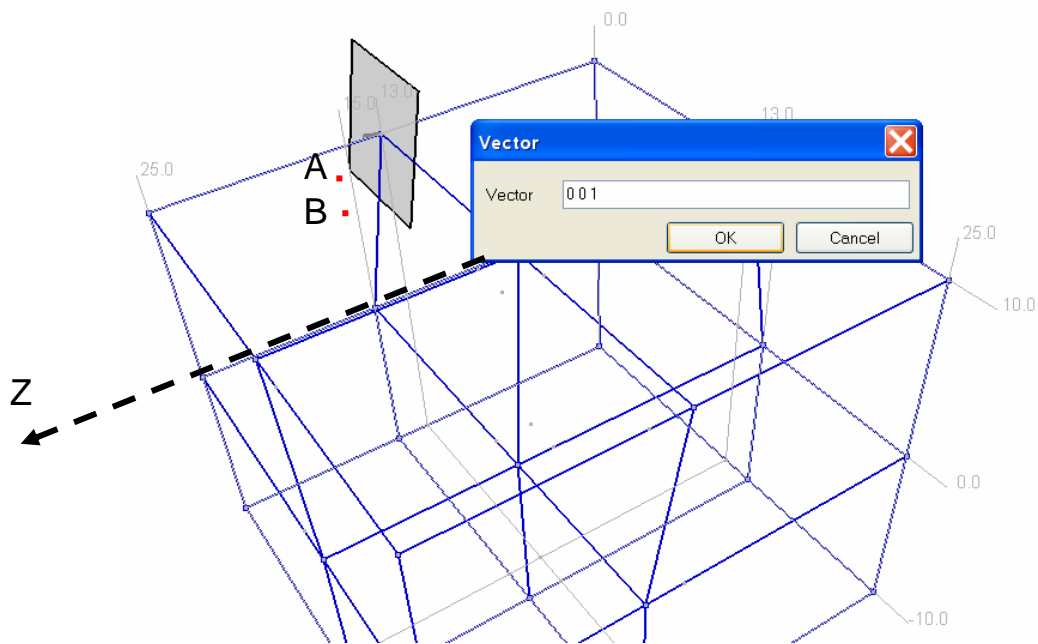

19 / 38

- 1 Now we will project the two points on the slope so we need to create an auxiliary projection plane
- 2 Use option (right menu) *Macromodel/Auxiliary Planes/Create../3nodes/points* and create the plane
- 3 Perform points projection on the plane in Z-direction (use method *Macromodel/Point/Update/Project.../On plane in direction* (vector { 0 0 1 }))
- 4 Nails are to be inclined at 20° and their length is 5m so we want to create a segment line 5m long (use method *Macromodel/Objects/Line/Create../by point extrusion* with vector { 0 -1.71 -4.70 })
- 5 To create a nail on the segment line we use method *Macromodel/Nail/Create../On objects* from the right menu and pick the segment by mouse
- 6 Note that by default a soil-nail interface is created (one may cancel its generation)



20 / 38

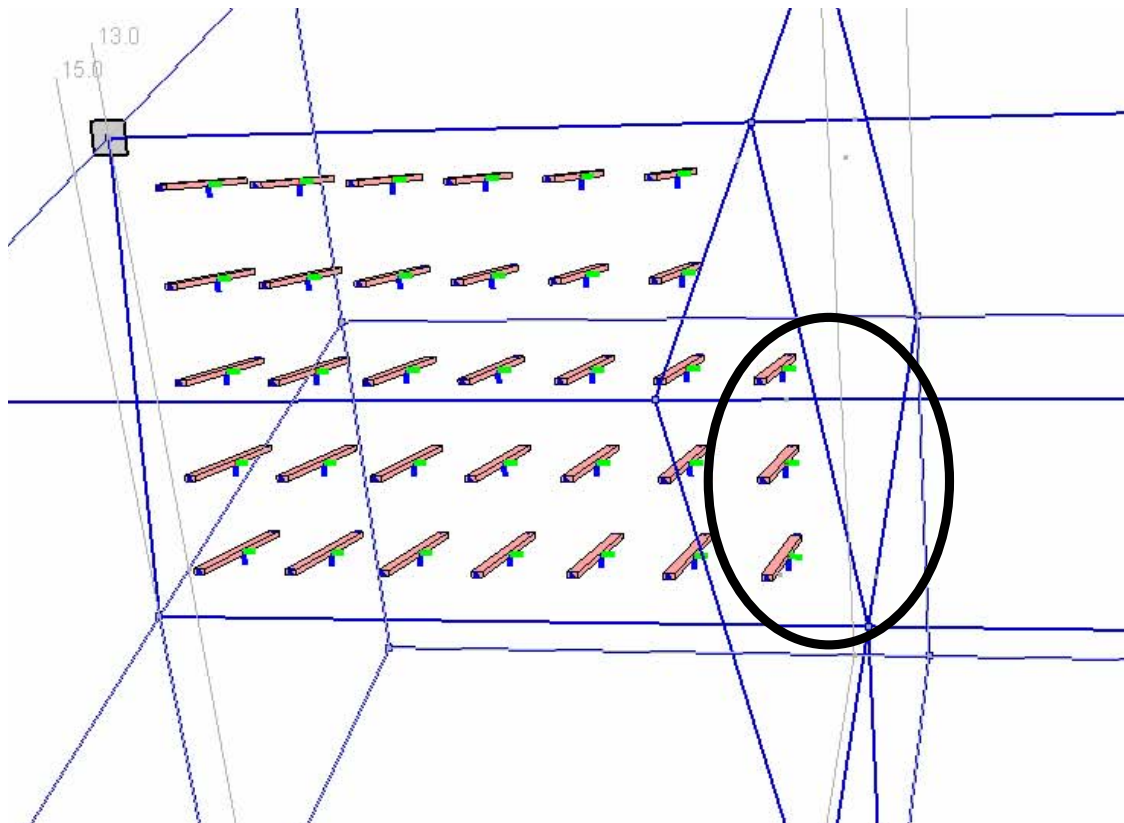

Copying nails in one direction



21 / 38

- 1 For further copy operation in the vertical direction we can find a vector (using the toolbar ) that will appear later on in all following copy operations
- 2 To find this vector we click on the icon  and then pick the two points (sometimes we will need to hide some objects that hide the point)
- 3 The first copy operation is performed in the Y-direction 4 times (steps) along predefined vector
- 4 The second copy operation must be performed on the selection of all nails in X-direction (vector $\{ 1 \ 0 \ 0 \}$) 5 times with step 2m
- 5 To finalize generation of nails on the first slope face let us add 3 nails at the bottom (by copying)

22 / 38



Copying nails by symmetry option

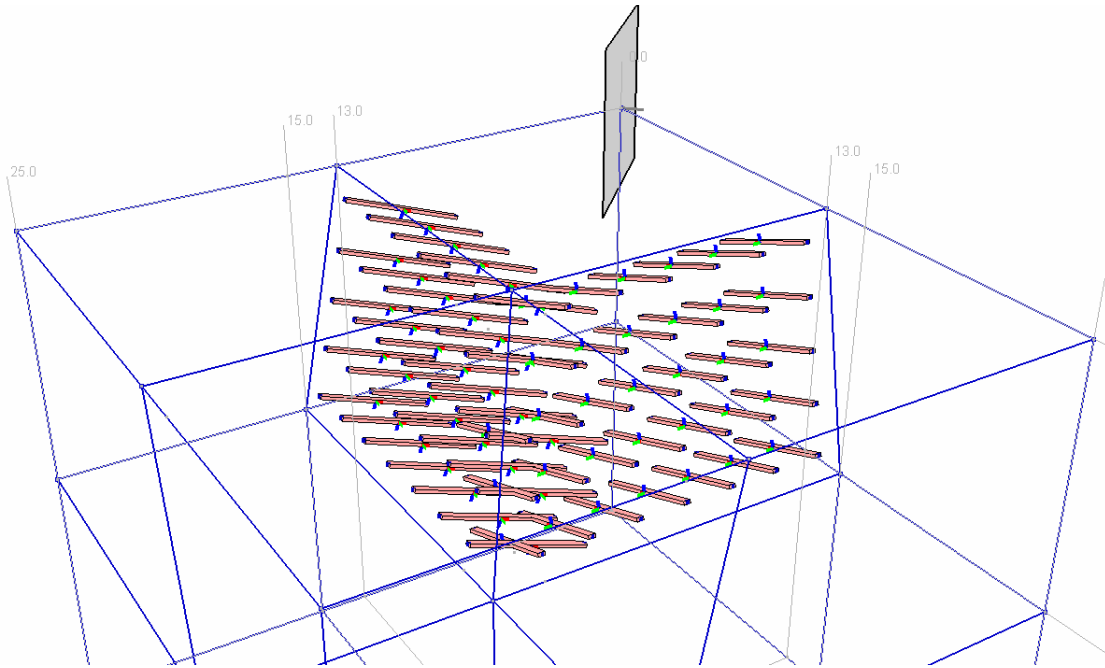

23 / 38

- 1 First we create symmetry plane
- 2 In the second step we perform copying of all selected nails via *Macromodel/Nail/Create/Copy by symmetry* method



24 / 38

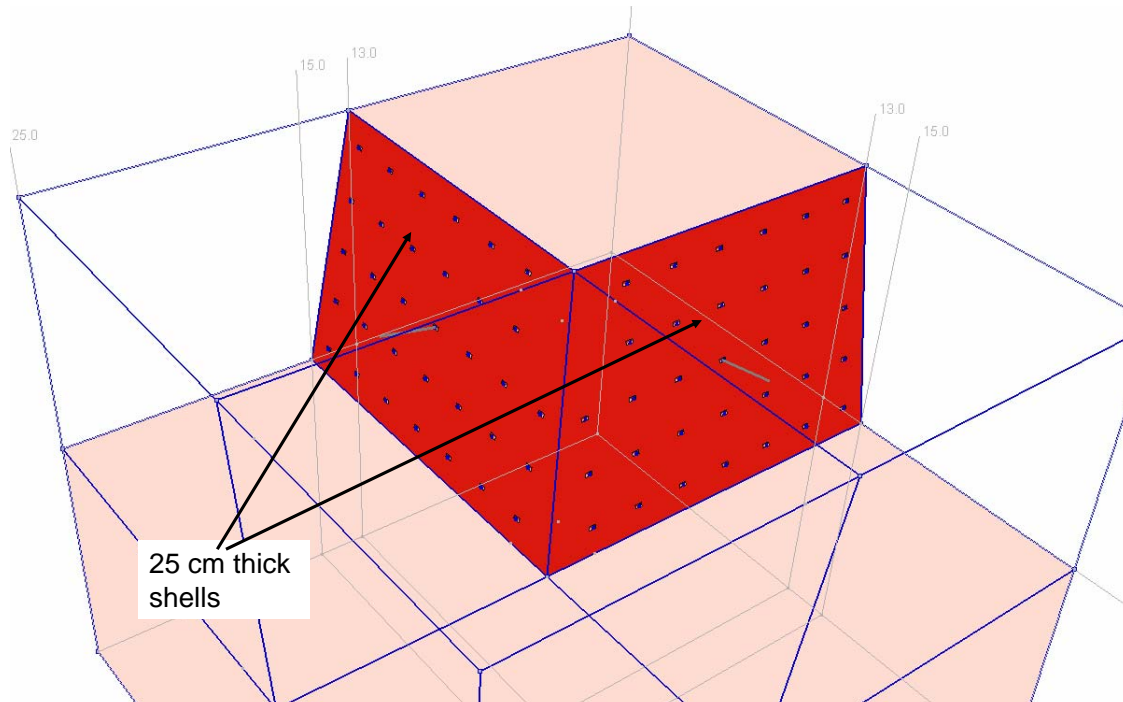

Adding facing walls



25 / 38

- 1 Now we need to add shell macroelements on 2 slope faces
- 2 To see them we must select 3 continuum subdomains and to hide them using the toolbar 
- 3 Once we can see these faces we select them using the  toolbar and then create shell subdomains using the method *Macromodel/Subdomain/Create/3D shell on faces* (thickness 0.25m)

26 / 38



Generating virtual mesh

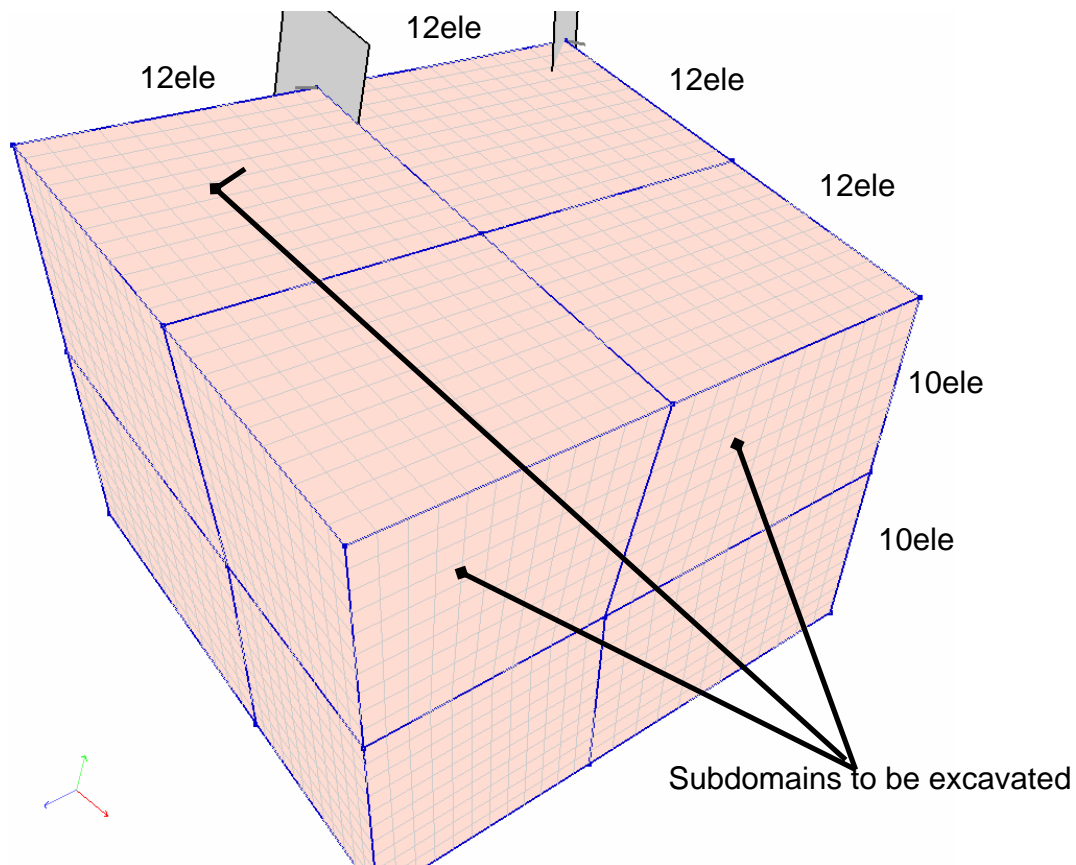

27 / 38

- 1 In this example the slope is constructed by excavation of 10m of subsoil
- 2 Hence the excavation will be carried out in 5 steps with a sequence that consists of excavation of a soil layer (2m), installation of a single row of nails and then adding a facing wall
- 3 The virtual mesh split is shown in the figure
- 4 This virtual mesh must also be created for the facing walls
- 5 Note that the nail endpoints do not need to coincide with the generated mesh

28 / 38



Automatic generation of existence functions for multi-step excavations

Existence functions

Function definition

Number	Name	time 1	time 2	time 3	time 4	time 5
11	NAIL+FACING WALL	0	2	10	10	10

Value

0.00

Export Import Automatic generation

Existence function definition

Update Existence function name

Existence function name: SOILLAYER

Start existence function number: 1

Increment of existence function: 1

Time increment: 2 [s]

Number of steps: 4

OK Cancel

29 / 38

- 1 To model multi-step excavation we need to define 5 existence functions for soil layers and 5 existence functions for nails and facing wall, if we assume that the facing wall is added at the same time as the nail
- 2 To speedup generation of these functions we can define the first existence function for the soil layer and the remaining ones can be created automatically by pressing **Automatic generation**
- 3 Same operation we perform for existence functions designed for facing wall

30 / 38



Applying existence functions to nails

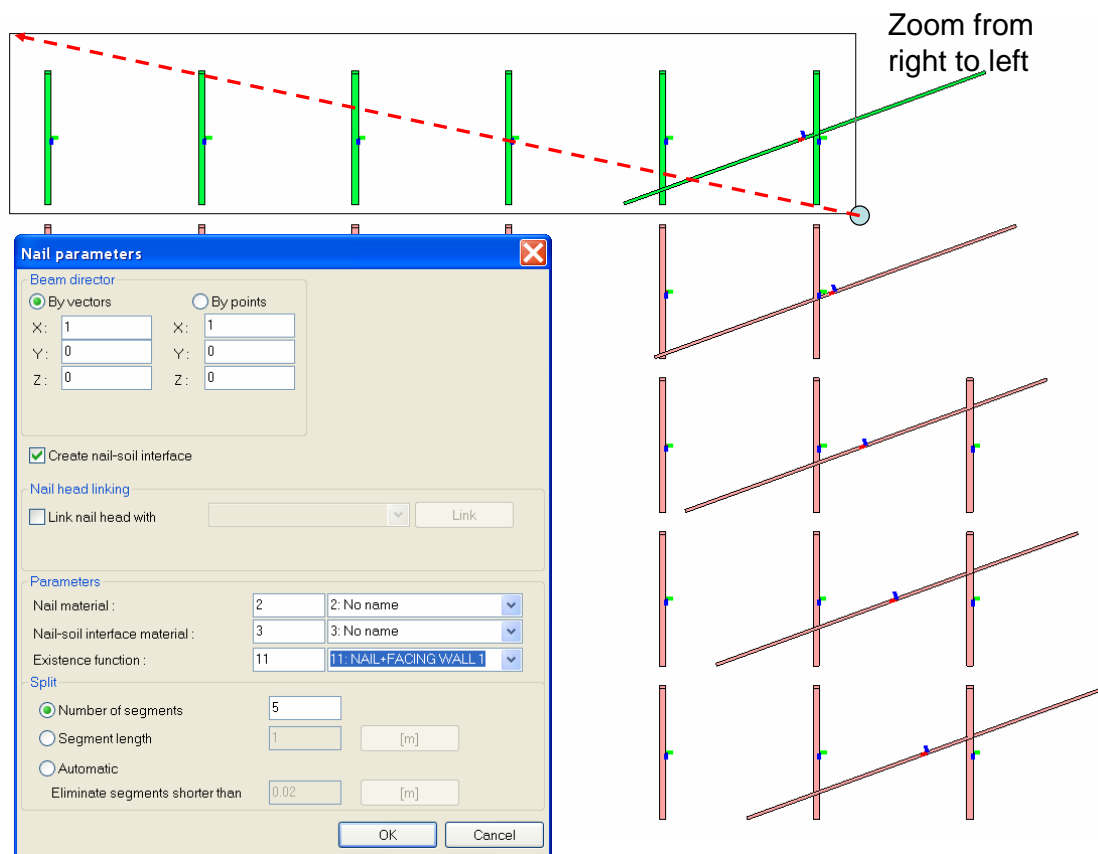

31 / 38

- 1 In order to get nails active at certain time instances we need to associate predefined existence functions with the nails
- 2 As each row of nails appears at a different time we have to select them row by row and to set the existence function
- 3 As the mesh size of the continuum in which we plug nails in is 5m long we can assume that the uniform split 5 for nails is good enough (we should try to make same mesh density in the continuum and in the nails, otherwise we may observe some spurious stress oscillations in the solution)
- 4 The best way to select them is to use orthogonal camera, make X-Y projection and to select nails by zoom box
- 5 To check whether the existence functions are applied properly one may activate the option *Existence function* instead of *Initial material* at the right bottom combo box

32 / 38

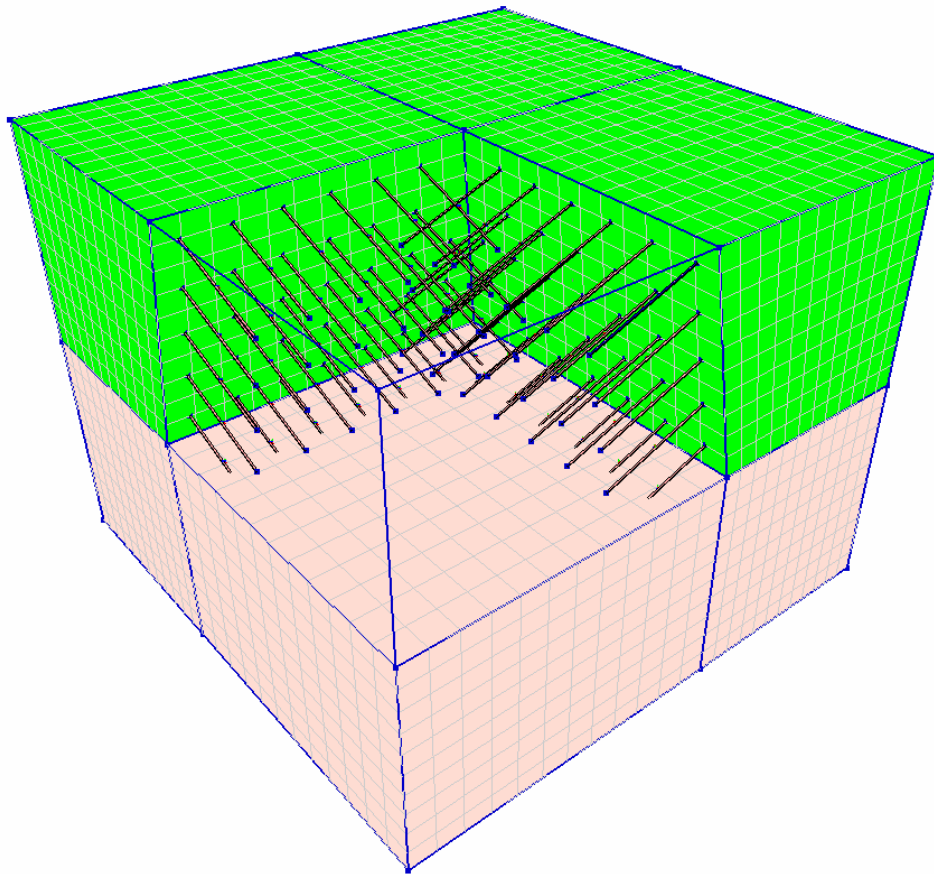

- 1 As the 3D continuum subdomains, nor shell ones, are not split in the vertical direction one way to model the excavation stage is to perform transition from the virtual to the real mesh and to apply existence functions to the selected sets of elements at the FE model level
- 2 To perform the operation fast we can select first the 3 continuum subdomains and all shell ones and to make virtual mesh → real mesh transformation exclusively for these objects (use option *Macromodel/Subdomain/Mesh/Virtual to real*)
- 3 Hide macromodel (Ctrl-M or find the corresponding option under *Visualization*)
- 4 Switch to orthogonal camera (it is important for zoom selections) and make X-Y projection
- 5 Switch the selection mode from *Add to selection* to *Replace selection*



Applying existence functions to continuum and shells cont...

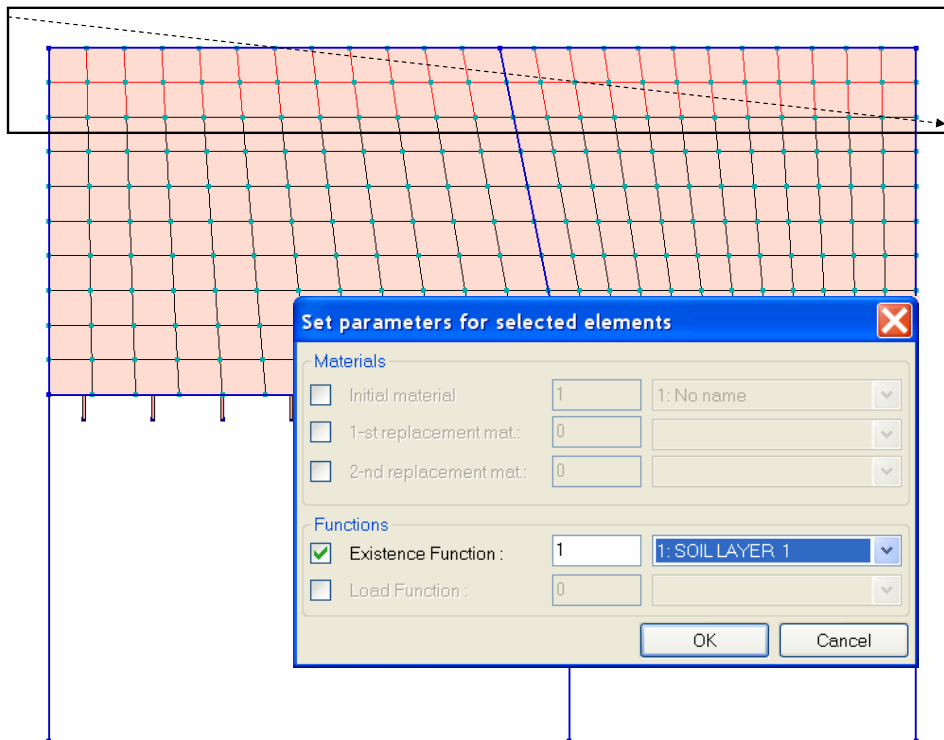

35 / 38

- 1 Go to the right menu, choose option *FE model/Continuum 3D/Outline by zoom box* and select row of continuum elements
- 2 Set the proper existence function using the option *FE model/Continuum 3D/Update/Parameters*
- 3 Same operation perform for shells but from *FE model/Shell one layer/....* menu
- 4 Verify if the stage construction/excavation setting is properly defined

36 / 38



Conecting nails to the facing wall

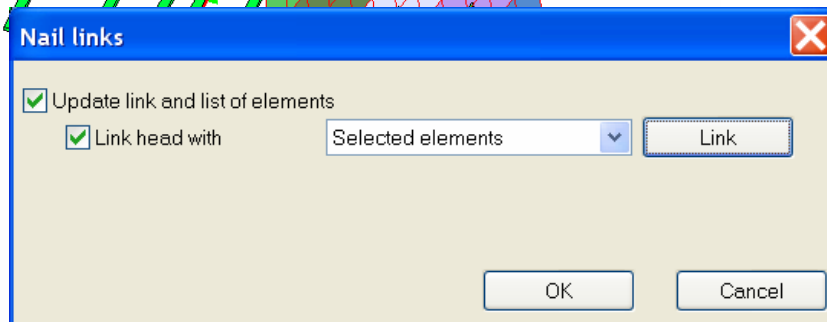
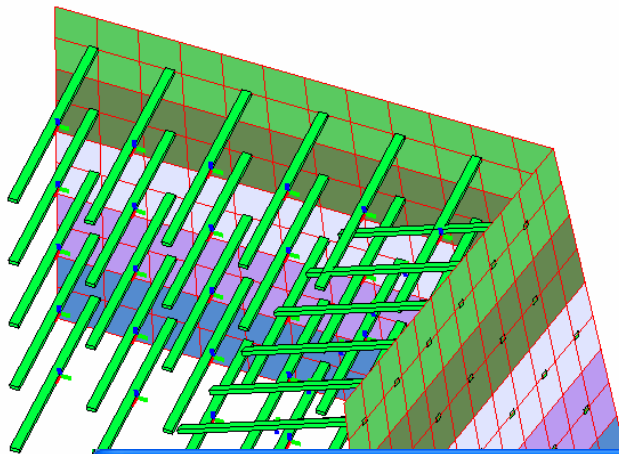

37 / 38

- 1 So far nails are not yet connected to the shells because their endpoints do not coincide with the shell element nodes, hence we have to attach head of each nail to the facing wall
- 2 To make this operation we come back to the macro-model level to the option *Nail*
- 3 Once all the nails are selected we use the option *Macromodel/Nail/Link nail head* and then by activating checkboxes as in the figure above we click on button **Link** and it is done

38 / 38